

IFBT4/E01

Frequency Agile IFB Transmitter

TECHNICAL DATA

- Digital Hybrid Wireless® technology (US Patent 7,225,135)
- 256 UHF frequencies in 100kHz steps
- 50 mW power output for long range use
- Pilot tone squelch control
- Multi-use XLR input jack
- Built-in microphone preamp
- DIP switch programmable intercom input
- Tx mute for frequency scrolling
- Multi-function LCD display
- Rugged machined aluminum construction

The Lectrosonics IFBT4 transmitter was designed for use in broadcast, motion picture, theater, and stage applications where extended operating range and high quality audio are essential. The transmitter can be used as a stand-alone device or patched directly into popular intercom systems.

Lectrosonics Digital Hybrid systems overcome channel noise in a dramatically new way, digitally encoding the audio in the transmitter and decoding it in the receiver, yet still sending the encoded information via an analog FM wireless link. This proprietary algorithm is not a digital implementation of an analog compandor but a technique that can be accomplished only in the digital domain, even though the inputs and outputs are analog.

The DSP algorithm can operate in the native, compandor-free hybrid mode with Digital Hybrid receivers, or in a compatibility mode for use with IFB R1a receivers. When used with the R1a receiver, the system operates in the analog IFB mode with compandor noise reduction. When used with Digital Hybrid receivers, the system can operate in the compandor-free hybrid mode.



The rear panel provides the audio input and programming DIP switches for intercom and audio input type along with power and antenna input jacks.



Microprocessor control provides user-friendly operation and eliminates transients at turn-on and turn-off. The transmitter RF output is muted in the TUNE mode to avoid generating interference in other wireless systems while scrolling up and down to change frequencies. In the XMIT mode, the output is turned on and the frequency cannot be changed.

The transmitter delivers 50 mW of output power which, when used with an efficient antenna, provides excellent operating range with the R1a belt-pack receiver. Indoors, the signal will penetrate various surfaces and reflect from others efficiently to extend operating range and reduce the need for critical antenna positioning.

A supersonic pilot tone signal controls the audio squelch on the R1a receiver to eliminate noise when the transmitter is turned off and it prevents the receiver from locking onto false signals. The pilot tone also eliminates noise in the receiver at turn-on and turn-off.

The LCD display is backlit for use in dimly lit conditions and is also highly visible in direct sunlight.

DIP switch settings on the rear panel provide direct compatibility with RTS and Clear Com intercom systems. A preamp stage is also included in the input stage to allow direct connection to dynamic microphones. Direct output at studio line level can also be fed directly into the transmitter.

The transmitter housing is rugged, machined aluminum with an electrostatic powder coating and an anodized finish. The unit is powered by 6 to 18 Volts DC via a locking connector. The supplied whip antenna is a detachable, locking 1/4 wavelength flexible, galvanized steel cable that connects to a 50 Ohm BNC connector on the rear panel.

Block Diagram

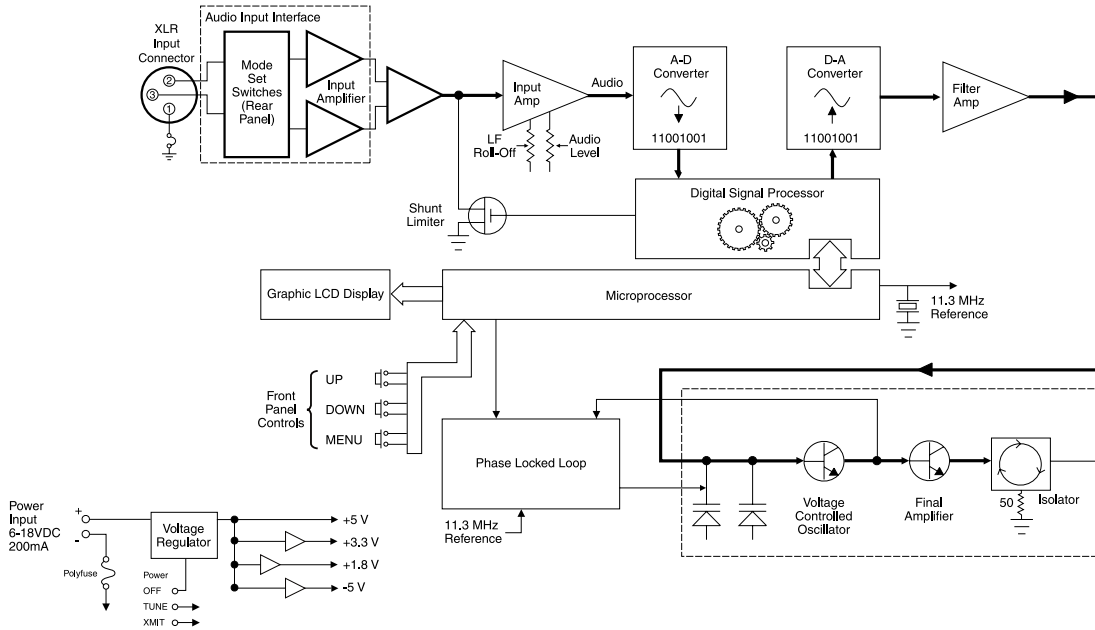

Specifications

Operating Frequencies (MHz):	Block 470 470.100 - 495.600 Block 19 486.400 - 511.900 Block 20 512.000 - 537.500 Block 21 537.600 - 563.100 Block 22 563.200 - 588.700 Block 23 588.800 - 614.300 Block 24 614.400 - 639.900 Block 25 640.000 - 665.500 Block 26 665.600 - 691.100 Block 27 691.200 - 716.700 (export only) Block 28 716.800 - 742.300 (export only) Block 29 742.400 - 767.900 (export only) Block 30 768.000 - 793.500 (export only) Block 31 793.600 - 819.100 (export only) Block 32 819.200 - 844.700 (export only) Block 33 844.800 - 861.900 (export only)
Frequencies (Channels per block):	256 (172 frequencies for Block 33 only)
Channel Spacing:	100 kHz (0.1 MHz)
RF Power Output:	50 mW
Spurious & Harmonic Suppression:	37 dB above 1 GHz
Frequency Stability:	±.001% (10 ppm) @ 25° C
Temperature Stability:	±.001% (10 ppm) from -30° C to +60° C
Operating Temp Range:	-30° C to +60° C
Channel Selection:	Momentary pushbutton switches, TUNE Up and Down
Pilot Tone:	<ul style="list-style-type: none"> • 29.997 kHz (IFB mode) 5 kHz deviation • 25 to 32 kHz (digital hybrid mode) 2 kHz deviation Unique pilot tone frequency for each selected carrier frequency in digital hybrid mode
Modulation:	FM, ±20 kHz deviation (±25 kHz max. in IFB mode) FM, ±50 kHz deviation in digital hybrid mode
Audio Frequency Response:	(overall system - see LF Roll-off) <ul style="list-style-type: none"> • 100 Hz to 8 kHz, ±1 dB, IFB mode • 100 Hz to 20 kHz, ±1 dB, digital hybrid mode
LF Roll-off:	Low frequency audio roll-off is Menu selectable for 3 dB down at 35 Hz or 50 Hz (IFB and digital hybrid modes)

Signal to Noise Ratio:	90 dB typical (system "A" weighted)
Audio Compressor:	2 to 1 (IFB mode)
Output Impedance:	50 ohms
Audio Input Levels:	<ul style="list-style-type: none"> • 0 dBu for Line, RTS1 & RTS2 • -10 dBu for Clear Com • -42 dBu for mic dry inputs (no phantom power) • +/-50Vdc max
Audio Input Config:	Balanced and Unbalanced, rear panel selectable for Line, Mic, RTS 1, RTS 2, and Clear Comm
Audio Input Impedance:	Greater than 2 K balanced, greater than 1 K unbalanced at any gain setting
Gain Control Range:	-18 dB to +24 dB (0 dB nominal center), Menu selectable
Audio Input Jack:	Standard XLR female connector
Input Power:	12 to 14 VDC typical, 200 ma. max.; Max. Input Range 6 to 18 VDC
Power Input Jack:	Coax type, locking LZR RL26AE
Indicators:	Backlit Liquid Crystal Display. Displays modulation meter, frequencies, modes, roll-off, audio level, and tuning groups.
Front panel controls:	<ul style="list-style-type: none"> • MENU momentary pushbutton switch • Power OFF-TUNE-XMIT, 3 position slide switch • Select Up momentary pushbutton switch • Select down momentary pushbutton switch
Rear panel controls:	Input Mode Select, 4 section DIP switch
Weight:	10 ozs.; 278 grams
Size (including connectors):	13.4 cm x 8.3 cm x 3.2 cm
<i>Specifications subject to change without notice.</i>	
Emission designator:	180KF3E

CE1313



581 Laser Road NE • Rio Rancho, NM 87124 USA • www.lectrosonics.com
 (505) 892-4501 • (800) 821-1121 • fax (505) 892-6243 • sales@lectrosonics.com